

MDT

Encoder Data Transceiver

Standard and MAX Range Systems

Product Overview

The Tehama Encoder MDT has a true encoder interface that directly reads the meter face value of encoded meters to transmit an absolute reading towards the DCAP. It auto-detects the data format between Sensus meters, Sensus compatible meters (Master-Meter, Badger, etc.), Neptune meters, and GWF ECO meters.

Our Encoder MDT is available in two radio technologies, our original Standard Range and our MAX Range system. The Standard Range is our original, first generation system, which we continue to fully support and maintain. Both are powered by two AA Lithium batteries with expected battery life up to eight years.

The Encoder MDT is also available with either a single input for single meter usage or dual inputs for co-located hot and cold water meters or other two-meter combinations.

Other variations and features are available such as:

- Submersible version for pit or outdoor installation (see Submersible Data sheet)
- Integrated Remote Display, California approved (See Display MDT Data sheet)

Specifications

Input	<ul style="list-style-type: none"> • -E: Sensus UI-1203 or Neptune, auto-detecting • -G: GWF AllRead UNICOCoder® Interface
MDT Data Storage	<ul style="list-style-type: none"> • No local storage
Data Resolution	<ul style="list-style-type: none"> • One hour interval
Radio	902 – 928 MHz; FCC and IC Certified for all modes <ul style="list-style-type: none"> • Standard: Open field range of one mile • MAX: Open field range approaching 10 miles
LED	Indicates on/off and RF network connection status. From button press: <ul style="list-style-type: none"> • Solid Green: good Link Quality • Solid Amber: OK Link Quality • Red or Flashing: poor Link Quality or syncing to Network
Operating Environment	-20 to 145 degrees F, up to 90% RH, non-condensing.
Power	Two AA Lithium batteries
Typical Battery Life	6-8 years @ 50 to 90 deg. F, reduced at temperature extremes
Dimensions	4.3" x 2.2" x 1.2"
Warranty	Five years. For more detailed information, please visit our warranty page . Note that the warranty does not cover batteries.

Continual product enhancements may cause specifications to change without notice.

*Actual range may vary depending on installation location and topography

Models

Standard System		
Single Encoder MDT	TW-160B-E	Single Encoded input, one-hour interval data
Single M-Bus MP MDT	TW-160B-G	Single GWF M-Bus MP Encoded Meter input, one-hour interval data
Dual Encoder MDT	TW-160B-EE	Dual Encoded input, one-hour interval data
Dual M-Bus MDT	TW-160B-GG	Dual GWF M-Bus Encoded Meter input, one-hour interval data
MAX System		
Single Encoder MDT	TW-170B-E	Single Encoded input, one-hour interval data
Single M-Bus MP MDT	TW-170B-G	Single GWF M-Bus MP Encoded Meter input, one-hour interval data
Dual Encoder MDT	TW-170B-EE	Dual Encoded input, one-hour interval data
Dual M-Bus MDT	TW-170B-GG	Dual GWF M-Bus Encoded Meter input, one-hour interval data

*: Adequate repeater coverage is required for guaranteed delivery.
Other combinations and sensor inputs are available by special order. Please contact Tehama for details.

****Note**** Standard and MAX Range systems are NOT compatible: only Max Range MDTs must be used with a Max Range Repeater (and Max Range DCAP) and vice versa for Standard.

Refer to [AN-119](#) in the documents section of our website for more information.

MDT Configuration

All MDTs come with a pre-set configuration; there are no settings to change on the MDT itself. Settings such as count factor or Units are set in our software.

New MDTs are shipped from the factory in a powered-off state. They can be powered on using a hidden button under the Tehama Wireless logo. The LED lights up when the button is pressed for visible feedback.



Turn ON or Off:

- Press & hold button until LED blips off (roughly 3 seconds), then release.
- Encoder MDTs check for a meter connection once a day and will turn on if a meter is detected.

Power-up LED Flashing at a 1 second rate:

- Indicates MDT / Repeater is listening for DCAP or other Repeaters.
- Once a beacon is heard, the flashing rate will double in speed.
- Once a Connection is established, the LED stays solid for 10 seconds.
- If the attempt to connect to all beacons fails, LED goes out after 60 seconds.

Check the status of an MDT or Repeater by tapping the button:

- Unit is OFF if you see 2 flashes after the button is released.
- Unit is Asleep (On but out of range) if you see 1 flash only. The button press will wake up the unit to try to re-connect to Network. Finding an MDT in the sleep state is usually an indication of poor placement or inadequate Repeater coverage.
- Unit is Connected and operating normally if the LED stays on for 10 seconds.
- Green indicates a robust radio link, Orange an OK link, and Red a poor link.

Reset Count:

- Press and hold button until power-up flashing sequence starts (12-15 seconds). The LED will blip off at the 3 second mark then go off for a few seconds at about 10 seconds.

MDT to Meter Wiring

TW-160/170/180 B-E & B-G Encoder (Sensus/GWF color order)

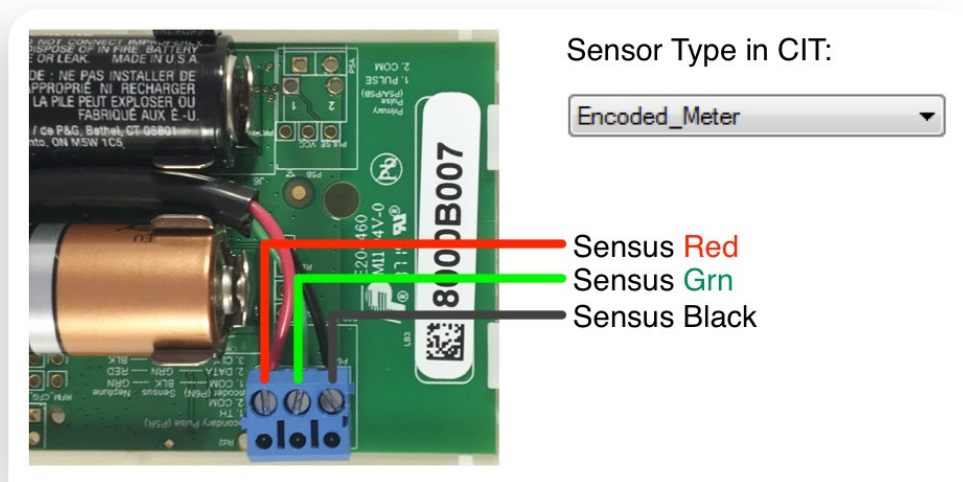

TW-160/170/180 B-EE & B-GG Dual Encoder (Neptune color order)

Important: The Encoder Primary/Secondary positions are opposite that used for Pulse meters. The Primary Encoder connector is in the position that is labeled Secondary Pulse on older boards.

Use the Sensus wiring order shown above for Sensus and compatible meters. The dual Encoder MDT can read two Sensus meters, two Neptune meters, or one of each.

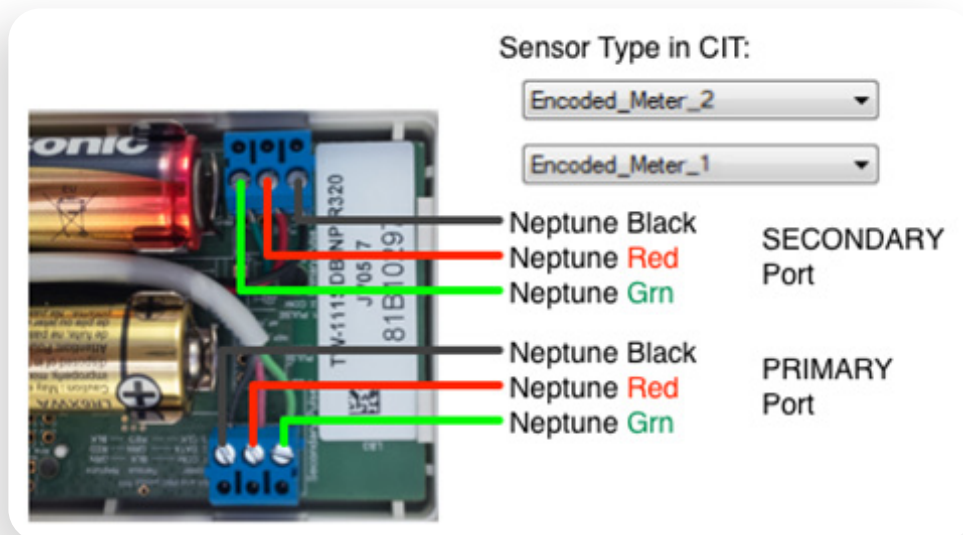

Note that you can swap the Meter connectors and the wiring order remains correct.

Device Placement

Warning: All radio devices should be placed at least 8 inches (20 cm) away from people in order to minimize RF exposure.

With the DCAP Unit powered up, the repeater backbone should next be placed. Start with units closer to the DCAP and use the Repeater LED feedback indication to verify the range is acceptable. At first, just the minimum numbers of repeaters need be placed; however, it is necessary that they be within range (solid 10 second LED "flash" when button pushed) for the backbone to be reliable. Repeater to Repeater (or DCAP) range in open field scenarios is measured in miles for our MAX system, however building construction materials, terrain, and poor location choices can reduce this down to hundreds of feet or less.

Once the initial Repeater placement is complete, the MDT placement phase begins. Again, the LED feedback can be used to verify that MDTs are communicating with the network. Additional repeaters can be placed in areas where MDTs are unable to connect to the backbone. MDT to Repeater (or DCAP) range in open field scenarios is in excess of a mile for MAX, or roughly 2000 feet for Standard. Again building construction materials, terrain, and poor location choices can reduce this down to a hundred feet or less.

The CIT software can also be used in the placement phase to provide more detailed information such as Link Quality and Signal Strength readings generated by MDT and Repeaters.

Wiring Instructions

Units should never be placed directly on a metal surface or within a metal enclosure. Mounting on a metal surface will significantly affect the radio performance of the device, be it an MDT or a Repeater.

Recommended placement

- Mount on nearby wall away from meter and copper /metal piping or conduit.
- RF performance is best when mounted on wallboard.
- Use keyhole shape to mount on screw in wall.
- Designed for #6 Drywall screw.
- Separate case to tighten screw if desired.
- Note Antenna Pattern shown on the right.
- Radio signal slightly attenuated along the long axis of the MDT case.

